

SIGMAX R19

SPECIFICATIONS

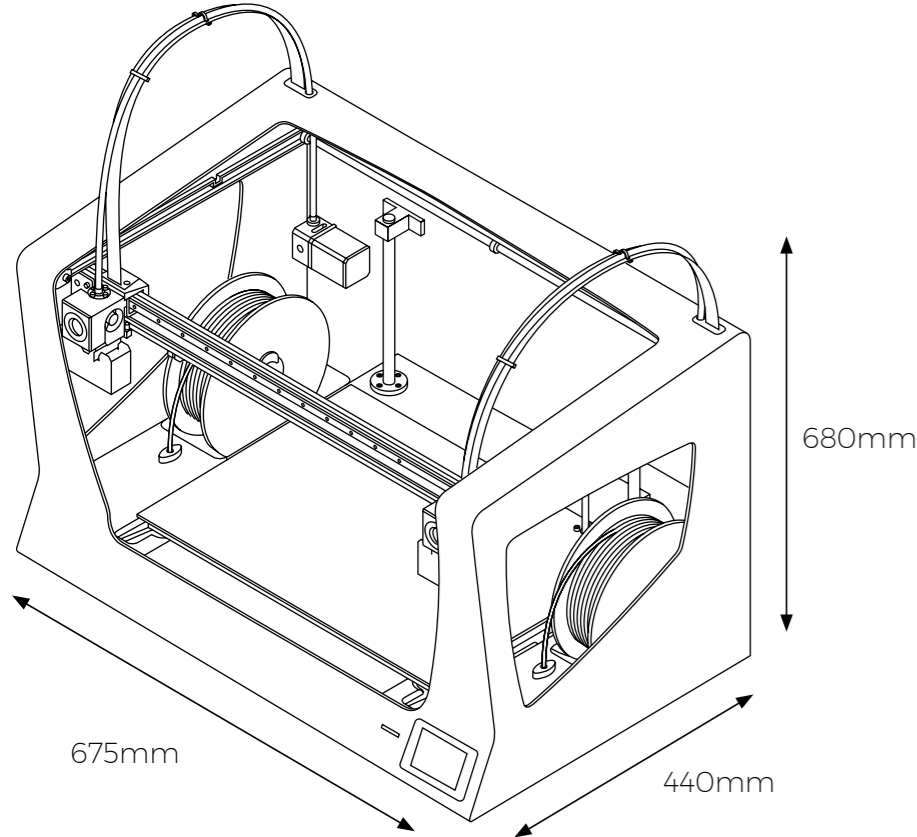

PRINTER PROPERTIES

Technology
Fused Filament Fabrication (FFF)

Architecture
Independent Dual Extruder (IDEX)

Printing volume
420mm x 297mm x 210mm

Extruders
2

Warranty
**2 years for EU countries.
1 year for non-EU countries.**

Extruder system
**Extruder Bondtech™ hight-tech dual drive gears.
Hotends: Optimized and manufactured by e3D™.**

Printing Models
**Regular
Dual-IDEX
Duplication
Mirror**

Electronics
**BCN3D Electronics v1.0
Independent Stepper Drivers**

Firmware
BCN3D Sigmax - Marlin

Heated bed
PCB

Screen
Full Color Capacitive Touchscreen

Supported files
gcode

Operating Sound
50 dB(A)

Nozzle diameter
0,3mm / 0,4mm (Standard) / 0,5mm (Special) / 0,6mm / 0,8mm / 1,0mm

Certifications
CE / FCC

Connectivity
**SD Card (autonomous)
USB**

PHYSICAL DIMENSIONS

Overall dimensions
675mm x 440mm x 680mm
(Including cables)

Weight: **20 kg**
(without filament spools)

Shipping box dimensions
550mm x 790mm x 674mm

Shipping weight: **24 kg**

MATERIALS

Filament diameter
2,85 ± 0,05 mm

Compatible Materials
**PLA
NYLON
PET-G
ABS
TPU
PVA
Composites
Others**

PRINTING PROPERTIES

Layer height
0,05 - 0,5mm
(depending on the nozzle diameter)

Positioning resolution (X/Y/Z)
1,25µm / 1,25µm / 1µm

Operating temperature
15°C - 35°C

Extruder maximum temperature
290°C

SOFTWARE

File preparation software
**BCN3D Cura (recommended),
Simplify3D, Slic3r**

Operative Systems
Windows, Mac, Linux

Supported files
STL, OBJ, AMF

Heated bed maximum temperature
100°C

ELECTRIC PROPERTIES

Input
AC 84-240V, AC 3,6-1,3A, 50-60Hz

Output
24V DC, 26A

Power Consumption
370W